

# 8820 Digital Thermostat

## U.C.I Heating and Control Equipment



Under Control Instruments Ltd

79-81 Chester Street

Aston

Birmingham, UK

B6 4AE

Tel: 0845 688 7122

Fax: 0845 280 6776

Email: [sales@undercontrol.co.uk](mailto:sales@undercontrol.co.uk)

Web: [www.undercontrol.co.uk](http://www.undercontrol.co.uk)

# 8820 Operating Instructions

## ☞ Main Function and Technique Index

### Main Function:

- ☞ **Refrigeration Controlling (Refrigeration / heat):** temperature display, temperature controlling (refrigeration/heat mode can be set), compressor start delay protection, temperature sensor error alarm.
- ☞ **Defrost Controlling:** 2 defrost modes (electric heat, hot gas), 2 defrost start mode (time alternation, accumulative compressor running time), 2 defrost end mode (timing, controlled by both temperature and time) dripping, manual defrost, defrost sensor error alarm.
- ☞ **External alarm:** one external alarm input, it can be set to 5 modes: always open, always open locked, always closed, always closed locked or forbidden.

### Main Technique Index:

- ☞ **Temperature display range:**  $-50\sim 150^{\circ}\text{C}$  (The resolution is  $0.1^{\circ}\text{C}$ )  
 $-58\sim 302^{\circ}\text{F}$  (The resolution is  $0.1^{\circ}\text{F}$ )
- ☞ **Power supply:** AC  $220\text{V}\pm 10\%$ , AC  $380\text{V}\pm 10\%$  50Hz, DC 12V or 24V (Refer to the wiring diagram)
- ☞ **Operating environment:** temperature  $-10^{\circ}\text{C}\sim 50^{\circ}\text{C}$ , humidity  $\leq 85\%$ .
- ☞ **Relay contact capability:** compressor 20A/250VAC, defrost 8A/250VAC (pure resistive load)
- ☞ **Temperature sensor:** NTC R25=5k $\Omega$ , B (25/50) =3470K
- ☞ **Executive standard:** Q/320585 XYK 01-2004 (8820-CTDA)

## 📖 Operating Guide

### Panel:



### ☞ What's the meaning of the index lights on the panel?

The function of the LED on the panel is showing below:

Index Light	Name	Light	Flash
	Temp Setting	In the state of temp setting	-
	Refrigeration	Refrigerating	Ready to refrigerate, in the state of compressor start delay protection
	Heat	Heating	Ready to heat, in the state of compressor start delay protection
	Defrost	Defrosting	Dripping or the state of compressor start delay protection
	-	-	-
	Alarm	-	Alarm state

### ☞ The meaning of the LED display

The LED usually shows temperature, if it shows "SHr", it means the temperature sensor is short, and "OPE" means the temperature sensor is open. The temperature and the alarm code (Axx) will show alternately when in the alarm state.

The code is showing below:

Code	Signification	Explanation
A11	External alarm	Alarm from external alarm signal, please refer to the internal parameter code "F50"
A21	Temperature sensor error	Open or short (showing "OPE" or "SHr")
A22	Evaporator sensor error	Open or short (showing "OPE" or "SHr" when press the key "▼"). If you don't need to use the evaporator sensor, you can use the F59 to close the alarm.

### ☞ How to set the temperature?

Press the key "set" for at least 2 seconds, then enter the state of temperature setting, here the LED displays the setting temperature, then using "▲" key or "▼" key can change the parameter (the

key“▲”adds 0.1°C, the key“▼”minuses 0.1°C, press and hold it over 0.5 seconds can add or minus rapidly) . After setting, press “set” again, then exit the state of parameter setting. (The setting temp range is limited by the parameters F13 and F14, please refer to the senior operation). Pressing the key “M” in the setting process means cancel and exit, but the setting value will not be saved.

#### 🔧 How to defrost manually?

When in the state of displaying current temperature, press the key “▼” and hold it at least 5 seconds, then the controller enters the defrosting state. In defrosting state, press the key “▼” and hold it at least 5 seconds again, this can finish the defrosting forcibly.

#### 🔧 How to read the temperature of the evaporator sensor?

When displaying current temperature, press “▼” key, Controller will display defrosting temperature. Loose “▼” key, then return to current temperature. Notice that if you press the key and hold it for 5 seconds, the controller will enter or exit the defrosting state forcibly.

#### 🔧 How to refrigerate (or heat) forcibly?

When displaying current temperature, the temperature is between “setting temperature – temperature difference” and “setting temperature + temperature difference”, the system may or not refrigerate, here you press the key “▲” and hold it for 5 seconds, the controller will enter the refrigeration state forcibly when in the refrigeration state, and stop refrigeration when the temperature is below “setting temperature – temperature difference”; the controller will enter the heat state forcibly when in the heat state, and stop heating when the temperature is above “setting temperature + temperature difference”.

#### ✓ **Advanced Operation**

Press the key “M” and hold it for 5 seconds, and if you have set the password, the LED display the “PAS” to hint you to enter the password, you can use the key “▲” and “▼” to enter the password, if the password is correct, the LED will display the parameter code, use “▲” or “▼” to select the parameter code, Pressing the “set” key can make it to show the value of the parameter after select the parameter, here you use “▲” or “▼” to set the parameter (pressing the key and not release can add or minus rapidly), then press the “set” key to return to the state of showing parameter code after finishing setting. Pressing the key “M” can exit the parameter setting state when display the parameter code, pressing the key “M” means cancel when in the process of setting parameter, and the parameter will not be changed.

Internal parameter code is showing below:

Sort	Code	Parameter Name	Range	Factory setting	Unit	Remark
Temperature	F11	Setting temperature	F14 – F13	0	°C/°F	The setting range is limited by F13 and F14
	F12	Temperature difference	0.1 – 20	1.0	°C/°F	Control the temperature difference, please refer to the temperature controlling
	F13	Max setting temperature	-58 - 302	302	°C/°F	Notice: the controller will follow the rule of $F14 < F11 < F13$ forcibly, if you find out that one parameter can not be adjusted, it is because the parameter is limited by other parameters, you must first adjust other parameters
	F14	Min setting temperature	-58 – 302	-58	°C/°F	
	F18	Evaporator sensor adjustment	-20 – 20	0.0	°C/°F	Adjust the evaporator sensor bias
	F19	Temp sensor adjustment	-20 – 20	0.0	°C/°F	Adjust the temperature sensor bias
Compressor	F21	Compressor delay time	0 -- 10	3	min	
	F29	Compressor controlling mode (temp controlling mode)	COOL / HEAT	COOL	-	COOL: refrigeration mode HEAT: Heat mode
Defrosting	F31	Defrost alternation time (Enable when F35=1 and 2)	0.1 – 99.9	12	hour	
	F32	Defrost end temperature	0.0 – 100	15.0	°C/°F	
	F33	Defrost time	1 -- 99	15	min	
	F34	Dripping time	0 -- 99	5	min	
	F35	Defrost start mode	OFF 1 -- 2	1	-	OFF: defrost is off 1: time alternation start 2: time alternation start, the alternation is compressor accumulative running time

	F36	Defrost stop mode	0 or 1	1	-	0:only controlled by time 1:controlled by both time and temp
	F37	Defrost heat mode	0 or 1	0	-	0: electric heat 1: hot gas
Alarm	F50	External alarm mode	0 -- 4	0	-	0: without external alarm 1: always open, unlocked 2: always open, locked 3: always closed, unlocked 4: always closed, locked
	F59	Whether use the evaporator sensor error alarm	YES / NO	YES	-	
System setting	F80	Password	OFF 0001 -- 9999	OFF	-	OFF means no password 0000 means clearing password
	F81	Temperature unit	C/F	C	-	C: Centigrade F: Fahrenheit
Testing	F98	Reserved				
	F99	Test self	<b>This function can attract all relays in turn, and please don't use it when the controller is running!</b>			
	End	Exit				

### \* Basic Operating Principle

#### Temperature controlling

The controller has 2 temperature controlling mode: Refrigeration and Heat(F29).Temperature controlling point is controlled by “setting temperature (F11, or press the “set” key for some time to set)” and “temperature difference(F12)”.In refrigeration mode, the controller begins to refrigerate when the temperature of the temperature sensor is over “setting temperature + temperature difference”, and it stops refrigerating when the temperature is under “setting temperature – temperature difference”; In heat mode, the controller begins to heat when the temperature of the temperature sensor is under “setting temperature – temperature difference”, and it stops heating when the temperature is over “setting temperature + temperature difference”

#### Compressor delay time

The compressor delay time is set by F21, for example, 3 minutes. The controller contains a “compressor halt calculagraph”, and it begins to time when compressor stops, the program first check the calculagraph before booting the compressor next time, the program will immediately boot the compressor if the calculagraph reach 3 minutes ,if the calculagraph doesn't reach 3 minutes ,it will boot again when the calculagraph reaches 3 minutes. Thus you can ensure that the boot alternation is over 3 minutes after halt, so it can prevent to breaking the compressor as a result of frequent boot. In addition, the controller doesn't boot the compressor within 3 minutes after turning on the power supply, thus the compressor can also be protected in the state of power cut and then power on.

### **Auto defrosting principle**

The controller has 3 defrost start modes which can be selected (F35) :

OFF: Defrost is off.

1. Time alternation: the controller will start defrost according to the setting alternation time which can be set in "Defrost alternation time (F31)".
2. Accumulative compressor running time: if compressor accumulative running time reaches the time which set in "defrost alternation time (F31)", the controller starts defrost.

The controller has 2 defrost end modes which can be selected (F36) :

0: time control: the defrost time can be set by F33, the controller will stop defrosting when it reaches the defrost time.

1: controlled by both time and temperature: the controller will check the defrost effect through evaporator sensor after starting defrost, If the sensor temperature reaches the "Defrost end temperature (F32)", the controller will turn off defrosting, if the defrost time is longer than "defrost end time (F33)", the defrosting will be turned off forcibly.

You can select 2 defrost heat modes (F37):

0: electric heat: the compressor stops and the defrost output is turned on (the defrost output controls the electric heater);

1: hot gas: the compressor and defrost output is turned on (the defrost output controls the valve).

### **Dripping**

A dripping time can be set (F34). For example, set the dripping water with 5 minutes, after finishing defrosting, in 5 minutes, compressor doesn't run, in this state, "Defrost" indicator light will flash. But in two conditions the controller can't enter the dripping state: one is finishing the defrosting manually, and the other is defrosting temperature sensor's error.

### **External alarm**

The controller can connect a switching value as external alarm source (Pin 4, 5), when the external alarm occurs, the controller stops, displays the alarm code "A11" and generates alarm output. External alarm signal has 5 modes (F50):

- 0: without external alarm
- 1: always open, unlocked
- 2: always open, locked
- 3: always closed, unlocked
- 4: always closed, locked

"Always open" means in normal state, external alarm signal is open, if closed, the controller will give an alarm; "Always closed" is on the contrary. "Locked" means that when external alarm signal becomes normal, the controller is still in the alarm state, and it needs to press any key to resume.

### **Password**

In order to prevent irrespective persons from changing the parameters, you can set a password (F80), and if you have set a password, the controller will hint you to enter the password after you press the key "M" for 5 seconds, you must enter the correct password, and then you can set the parameters. If you don't need the password, you can set F80 to "OFF". Notice that you must remember the password, and if you forget the password, you can not enter the set state.

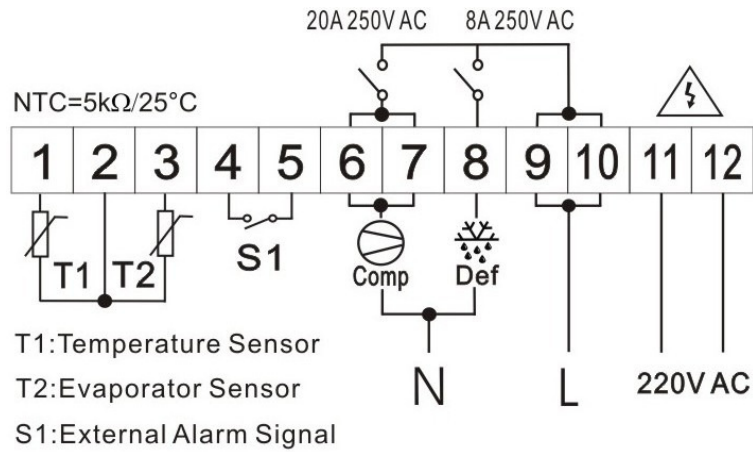
**Wiring Diagram:****Notice:**

1. Please read the guide carefully before using, and set the parameter accurately.
2. Please place the temperature sensor at the place of air return of the air-cooler.
3. The evaporator sensor must be fixed on the air return pipe of the evaporator, and if you don't use the evaporator sensor, please set the F59 to NO, or the controller will generate alarm.
4. Please use the temperature sensor which is supplied by our company.